

RESTARTING INJECTOR



GIUDICI
Sistema Standard

Modello Restarting DN	<input type="checkbox"/>	PN	<input type="checkbox"/>
Matricola n.	<input type="checkbox"/>	Anno	<input type="checkbox"/>
Colata n.	<input type="checkbox"/>		

AFL 7/4

G

353

RESTARTING INJECTOR

STEAM JET SUCTION PUMP

Operators of the old type of steam boilers (steam engines like steam locomotives, steam rollers, steam boats, steam cars, steam tractors, stationary steam engines) now have available new steam jet pumps that stand out from our competitors' products for their reliability and extraordinary simplicity along with an exceptional quality/price ratio.

Our **Restarting Injectors** comply with the requirements of PED Directive 2014/68/UE and are the result of OFFICINE GIUDICI's experience in this field since 1932.

Old steam jet pumps that are often subject to irreparable wear, can now be replaced with new parts distinguished by functional safety and winning design, recognising the developments in technology.

Individual items are available to be purchased as spare parts.

We also offer a maintenance service for all the appliances produced and sold over the last 50 years.

HISTORY

In 1858 Henry Gifford, a young French engineer, made a breakthrough when he invented a device capable of pushing water into the boiler.

Initially, operators used hand or steam operated pumps to keep the boiler's level up.

The hand pump required continuous hard work. The most common steam pump is driven directly from the cross head as the engine runs. The crosshead steam pump can only be used to keep the water level constant once the engine is running, it cannot be used to fill a cold boiler. When the water level was low in older railway locomotives, (which only had a cross head pump) the crew would sometimes have had to uncouple the train and run the engine back and forth to bring up the boiler level.

Gifford's device took a while to catch on, it seemed like it worked by magic, because it felt like the extra energy came from nowhere.

After some initial scepticism resulting from the unfamiliar and superficially paradoxical mode of operation, the injector was widely adopted as an alternative to mechanical force pumps.



Photo courtesy Andreas Precker (DE)



Photo courtesy Andreas Precker (DE)

RESTARTING INJECTOR

OPERATING

Restarting injectors, operating without moving parts, use steam to force water into the boiler against its pressure.

By opening the lever, the steam enters through an expanding nozzle, reduces its pressure and increases its speed.

Fresh water is sucked in and mixed with steam. As the steam condenses, it greatly reduces in volume, creating a vacuum which draws more feed water into the convergent combining cone.

As the pressure-drop is created, it closes the shutter valve avoiding an air inlet. The condensate mixture then enters a divergent delivery cone. Here the water expands, and its kinetic energy is converted into pressure and opens the non-return valve exceeding the pressure of the boiler.

An overflow is required for excess steam or water to discharge, particularly at the beginning. Indications of a working injector are a dry overflow pipe and rising water level in the boiler as indicated by the glass level gauge.

They are thermally efficient because virtually all the heat energy contained in the steam is returned to the boiler.

Most railway locomotives will have at least two installed in case of failure.

If the inlet water sucked by the injector is temporarily interrupted by the introduction of air which causes the opening of the overflow valve, the injector will automatically restore the flow without the need to adjust any valve.



Restarting Injector - Bronze

FEATURES

Body: Bronze or black painted cast iron (high temperatures resistant)

Nozzles, cones, and internal parts: bronze

Steam opening handle options: brass – wood - bakelite

Operating pressures:

- Model PN 16 - from 4 to 12 bar
- Model PN 25 - from 6 to 16 bar

Operating Pressure – both models are available in sizes 4 (only model PN 16), 5, 6, 8, 10, 12 and 15, depending on the required flow rate.

PERFORMANCE AND WEIGHT:

SIZE	4	5	6	8	10	12	15
DN	20	25	32	40	50	65	80
FLOW RATE (l/h)	1.300	2.200	3.300	5.000	8.000	12.000	18.000
WEIGHT (kg)	8	10	14	17	24	35	54



Photo courtesy J. David, ASSOCIATION DU CHEMIN DE FER DE RILLÉ (FR)

RESTARTING INJECTOR

INSTALLATION AND OPERATING INSTRUCTIONS

INSTALLATION

The pipes and valves must have the same diameter as the injector. Before installation they must be thoroughly cleaned with steam or compressed air to eliminate dirt and all other impurities as foreign bodies or residue that could damage the injector. The gaskets must not reduce the cross sections and therefore the flow rate, therefore it's important to check that pipes and joints are always perfectly tight. The motive steam pipe should be on an independent line, and connected to the boiler at the highest possible point. The steam pipe must be insulated to ensure the supply of dry steam. Wet steam impairs the efficiency of the injector and can damage the nozzles and cones. The pressure of the steam supplied must be the same as the recommended operating pressure of the injector. The inevitable curves must have the widest possible curvature. The water supply must be as cold as possible, and in no case hotter than 40°C. The injector can be installed either horizontally or vertically. In the case of horizontal installation, the water must be supplied from the bottom. It is advisable not to exceed a maximum hydrostatic head of 3 meters, if higher, the water suction pipe should be one size larger.

OPERATIONS

The steam opening lever must remain in the "off" position. To start operation, open the water, then slowly open the steam lever. If water continues to come out of the overflow, throttle the steam supply until it stops and hot water is pushed into the boiler. During this operation the noise of the water flowing can be distinctly heard. To interrupt operations, firstly close the steam supply and then turn the steam lever to "off" so that the flow of water is interrupted. The injector must operate for as short a time as possible and therefore with greater frequency to minimize the supply of large quantities of colder water in the boiler and thus avoid overheating the injector. It is preferable to blow steam through the injector at the end of the day for about 20 seconds to try to maintain its clean condition.



Photo courtesy H.R. Sennhauser, ZÜRCHER MUSEUMS-BAHN (CH)



Photo courtesy J.Van Landschoot - PAIRI DAIZA SA (BE)

SPARE PARTS

All spare parts can be ordered from the manufacturer. We recommend to order parts subject to wear in advance. When orifices become enlarged, the injector will work improperly and the only way that can resolve this issue is to replace the damaged cone with a new part.

DIAGNOSTICS

- Insufficient steam pressure or flow rate or wet steam
Please, check the operating conditions and restore the injector to the suggested parameters.
- In case of Scaled Up Cones
They are made to a very fine tolerance and prolonged use over time can deform their geometry, if these conditions occur, please replace the deteriorated elements.
- Lack of water supply or a leaky feed water pipe
Check the water level in the tender. Leaky joints or pipes are particularly troublesome; when the air passes in, it keeps the steam-jet from forming a vacuum. Please, drive a hydraulic pressure test and check the joints sealing.
- In case the feed water is too hot
When it is more than 40°C, it must be cooled down adding cold water in the tank.
- Injector overheating
When the injector gets too hot, it doesn't work. If overheating occurs, the cause is possibly a leaky steam valve. Please, run cold water through the injector body to cool it down and replace the valve.

MAINTENANCE

For maintenance operations, shut down the boiler and disconnect all the pipes. Then loosen the four screws on the body and raise the upper part with the steam opening lever. It is important that no elements fall into the injector or downwards damaging the cones. If the boiler is out of service for a long period of time, eliminate the water from the injector, above all in the case of severe frost. Any modifications to the injector and/or non observance of the instructions above relieves the manufacturer from any responsibility of the product, transferring all liability vis-à-vis third parties in the case of damage to the boiler operator.

RESTARTING INJECTOR

VERTICAL INSTALLATION

RIGHT

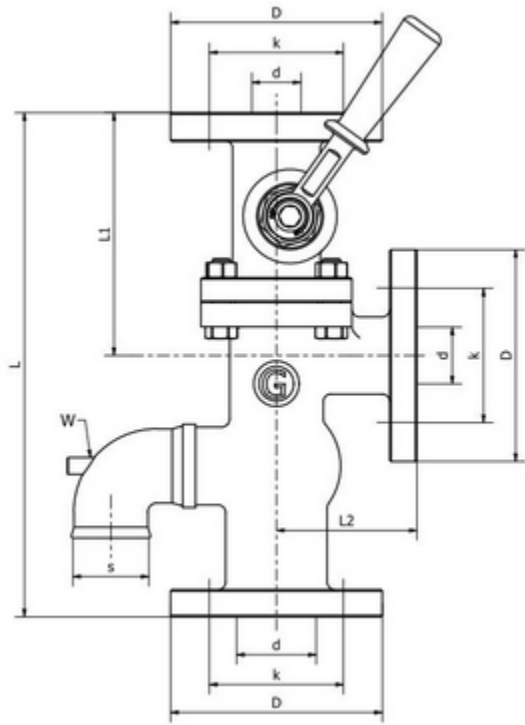

Option W: inspectable shutter valve

LEFT

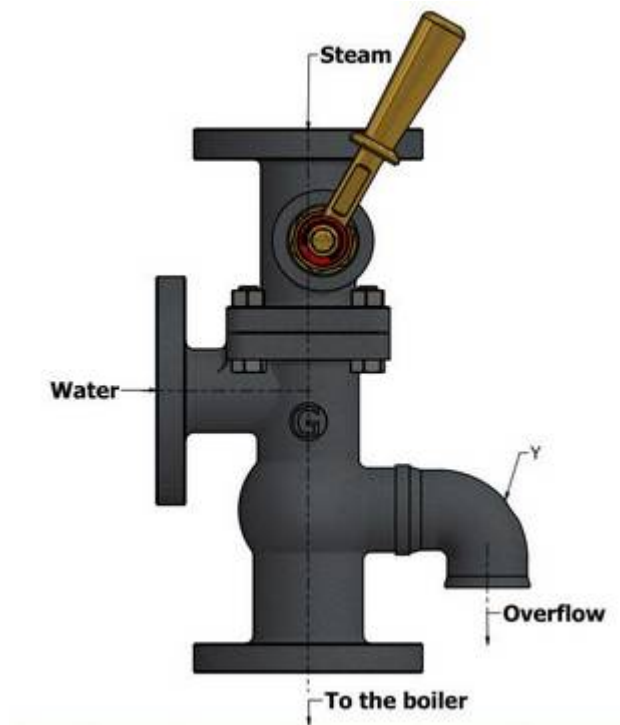

Option Y: not inspectable shutter valve

DIMENSIONS

SIZE	d	K	D	S	L1	L2	L
4	20	75	105	3/4	130	70	280
5	25	85	115	1"	150	80	315
6	32	100	140	1"1/4	160	90	340
8	40	110	150	1"1/2	170	105	380
10	50	125	165	2"	205	120	450
12	65	145	185	3"	235	125	510
15	80	160	200	4"	264	170	622

Dimensions of flange connections according to EN 10204 PN16/25

HORIZONTAL INSTALLATION

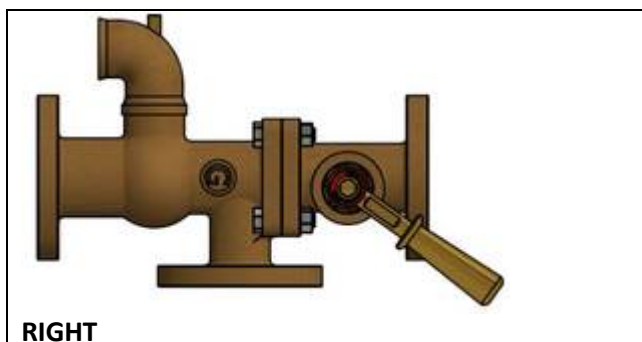

RIGHT

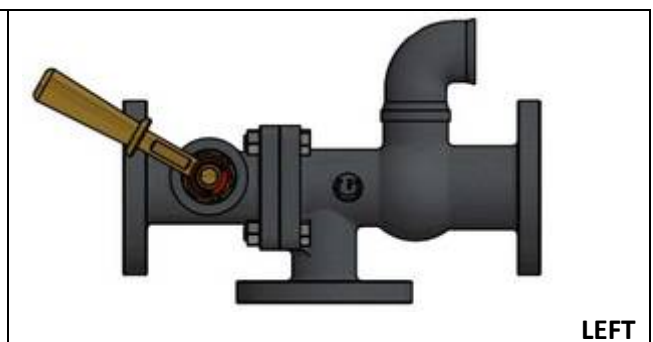

LEFT

OFFICINE GIUDICI S.R.L.
Via De Ruggiero 17 - 20019 Settimo Milanese (MI) ITALY
Tel. +39 02 3281 398 - info@officinegiudici.it

www.officinegiudici.it

