

## STEAM JET LIQUID HEATERS

### Installation outside tanks



The Steam jet liquid heaters are used to heat liquid via steam. The heating occurs thanks to the direct steam condensation inside the liquid.

When the steam jet liquid heaters are linked to the steam and liquid piping, they create continuous circulation inside the tank.

These kinds of heaters consist of two parts: a body and a removable nozzle. Simple and at the same time robust, these steam liquid heaters work without any other movement produced by internal parts, therefore they do not wear out or require any maintenance.

A typical application for this kind of device is in the food sector, it can be used inside the blanching tanks in slaughterhouses

#### Materials

Flanged connection UNI EN 1092 PN16  
 $\varnothing 1/2 \div 2''$

- Body in cast iron GG20, motive nozzle in stainless steel AISI 304.
- Body and nozzle in stainless steel AISI 304.

Specific materials on demand.

#### Operation

Steam enters into the heater through a nozzle that transforms pressure into kinetic energy.

To be heated, the liquid is sucked inside the body through the aspiration flange by the depressurisation created below the nozzle.

The steam releases the heat by condensing into the liquid that exits after each cycle at a higher  $\Delta T$  temperature than the one at the beginning of the process.

The succession of this continuous thermic exchange causes the gradual heating of the liquid.

The maximum temperature of the water to be heated is 80°C. Beyond this value, noise and vibrations may occur.

The liquid level must be at least 0.5 m above the heater water drain.

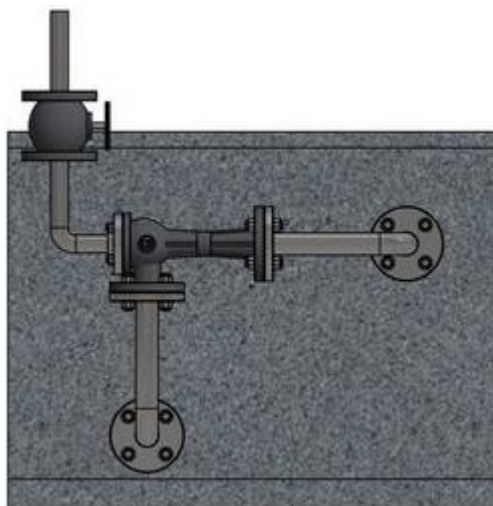
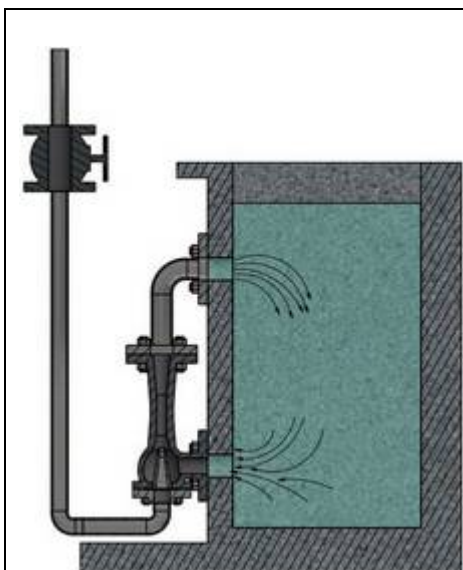

**Flow rate chart**

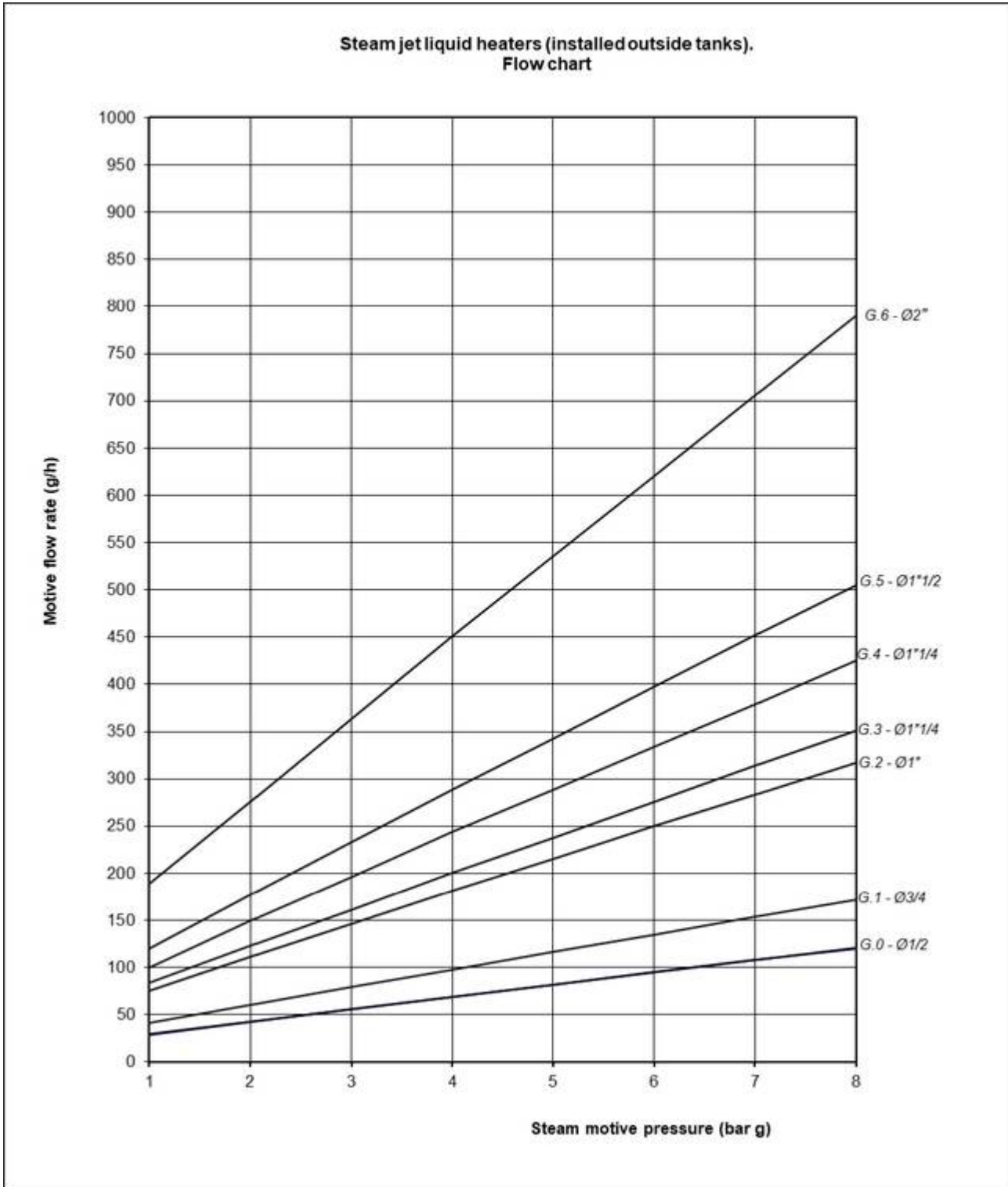

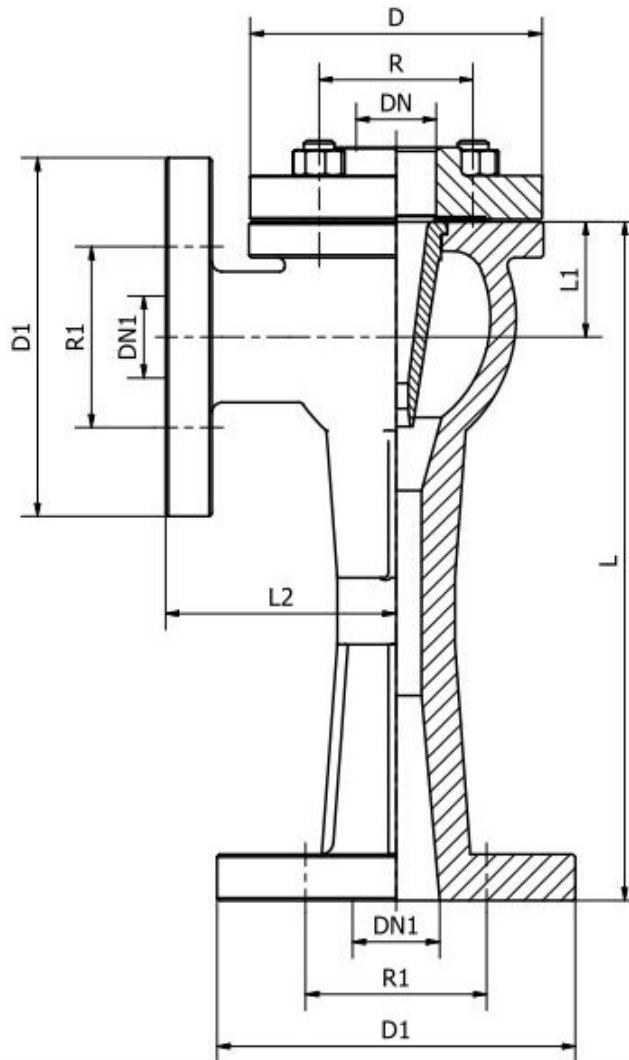
**Overall dimensions**

Grand.	DN	R	D	dn1	R1	D1	L	L1	L2
0	½"	65	95	20	75	105	205	165	80
1	¾"	75	105	25	85	115	220	180	85
2	1"	85	115	32	100	140	265	220	90
3	1" ¼	100	140	40	110	150	290	245	110
4	1" ½	110	140	40	110	150	310	265	115
5	1" ½	110	150	50	125	165	355	300	125
6	2"	145	185	65	145	185	400	330	125

**OFFICINE GIUDICI**

VIA DE RUGGIERO, 17 - 20019 - SETTIMO MILANESE (MI)

TEL. +39 02 32.81.398 - FAX +39 02 33.512.979

[INFO@OFFICINEGIUDICI.IT](mailto:INFO@OFFICINEGIUDICI.IT) - [WWW.OFFICINEGIUDICI.IT](http://WWW.OFFICINEGIUDICI.IT)